

**OUTSIDE MICROMETERS,
Interchangeable Anvil
Series 104**

Ref. No. 104-1A-1986-FEB

**104シリーズ(OMC)
替アンビル式外側マイクロメータ**

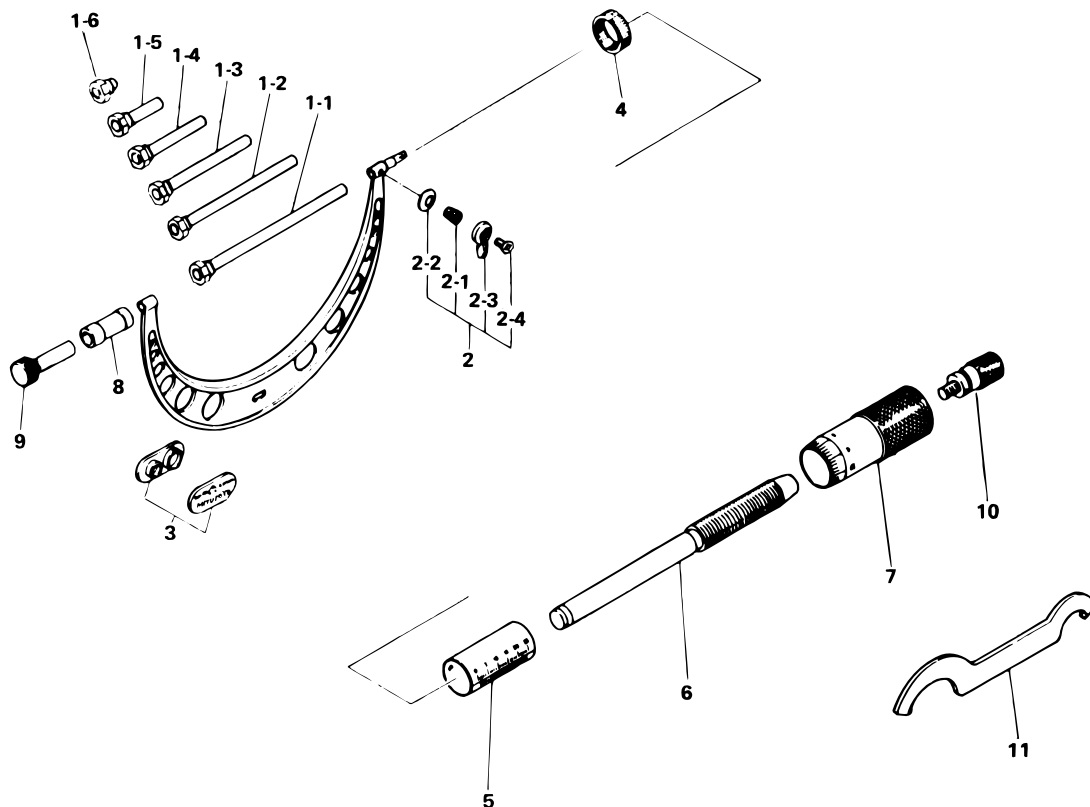

KEY NO.	PART NAME	CODE NO. コードNo.										ブヒンメイ	キー No.
		104-139 (OMC-100)	104-140 (OMC-200)	104-141 (OMC-300)	104-135 (OMC-150)	104-136 (OMC-300)	104-105 (OMC-100W)	104-106 (OMC-200W)	104-107 (OMC-300W)	104-101 (OMC-150W)	104-102 (OMC-300W)		
		104-149 (OMC-4")	104-150 (OMC-8")	104-151 (OMC-12")	104-137 (OMC-6")	104-138 (OMC-12")							
	ANVIL SET(METRIC)	980703				980704	980707 CARBIDE TIPPED			980708	アンビル (ミリ)		
1-1	No.1					303950				303961	No.1	1-1	
1-2	No.2					303951				303962	No.2	1-2	
1-3	No.3	303952							303963		No.3	1-3	
1-4	No.4	303953							303964		No.4	1-4	
1-5	No.5	303954							303965		No.5	1-5	
1-6	No.6	303955							303966		No.6	1-6	
	ANVIL SET(ENGLISH)	980705				980706					アンビル (インチ)		
1-1	No.1					303956					No.1	1-1	
1-2	No.2					303957					No.2	1-2	
1-3	No.3	303958									No.3	1-3	
1-4	No.4	303959									No.4	1-4	
1-5	No.5	303960									No.5	1-5	
1-6	No.6	303955									No.6	1-6	
2	CLAMP ASSY					950277					クランプクミタテ	2	
2-1	CLAMP SCREW					200867					クランプネジ	2-1	
2-2	SPRING WASHER					200420					スプリングワッシャ	2-2	
2-3	CLAMP HANDLE					200425					クランプハシユ	2-3	
2-4	SETSCREW					200424					トメネジ	2-4	
3	NAMEPLATE(METRIC)	950522	950538	950544	950535	950541	980327	980328	980329	980330	980331	ネームプレート (ミリ)	3
	NAMEPLATE(ENGLISH)	950547	950539	950545	950536	950542	950548	950540	950546	950537	950543	ネームプレート (インチ)	
4	NUT, ADJ					200415						テーパナット	4
5	SLEEVE (METRIC)					200117						ガイトウ (ミリ)	5
	SLEEVE (ENGLISH)					200116						ガイトウ (インチ)	
6	SPINDLE (METRIC)					200127						スピンドル (ミリ)	6
	SPINDLE (ENGLISH)					200128						スピンドル (インチ)	
7	THIMBLE (METRIC)					200124						シンブル (ミリ)	7
	THIMBLE (ENGLISH)					200125						シンブル (インチ)	
8	BUSHING, ANVIL					303972						アンビルブッシュ	8
9	SCREW, CLAMP					303973						シメツケネジ	9
10	RATCHET STOP					950700						ラチェット	10
11	SPANNER					301336						スパナ	11

104 OUTSIDE MICROMETERS,
Interchangeable Anvil
Series 104

Ref. No. 104-1A-1986-FEB

104シリーズ(OMC) **104**
替アンビル式外側マイクロメータ