

**OUTSIDE MICROMETERS,
Series 105
Slide Anvil Type, Light Duty Pipe Frame**

Ref. No. 105-2-1984-NOV

**105シリーズ(OMS₁-P,OMS₂-P)
軽量パイプフレーム外側マイクロメータ
スライドアンビル式**

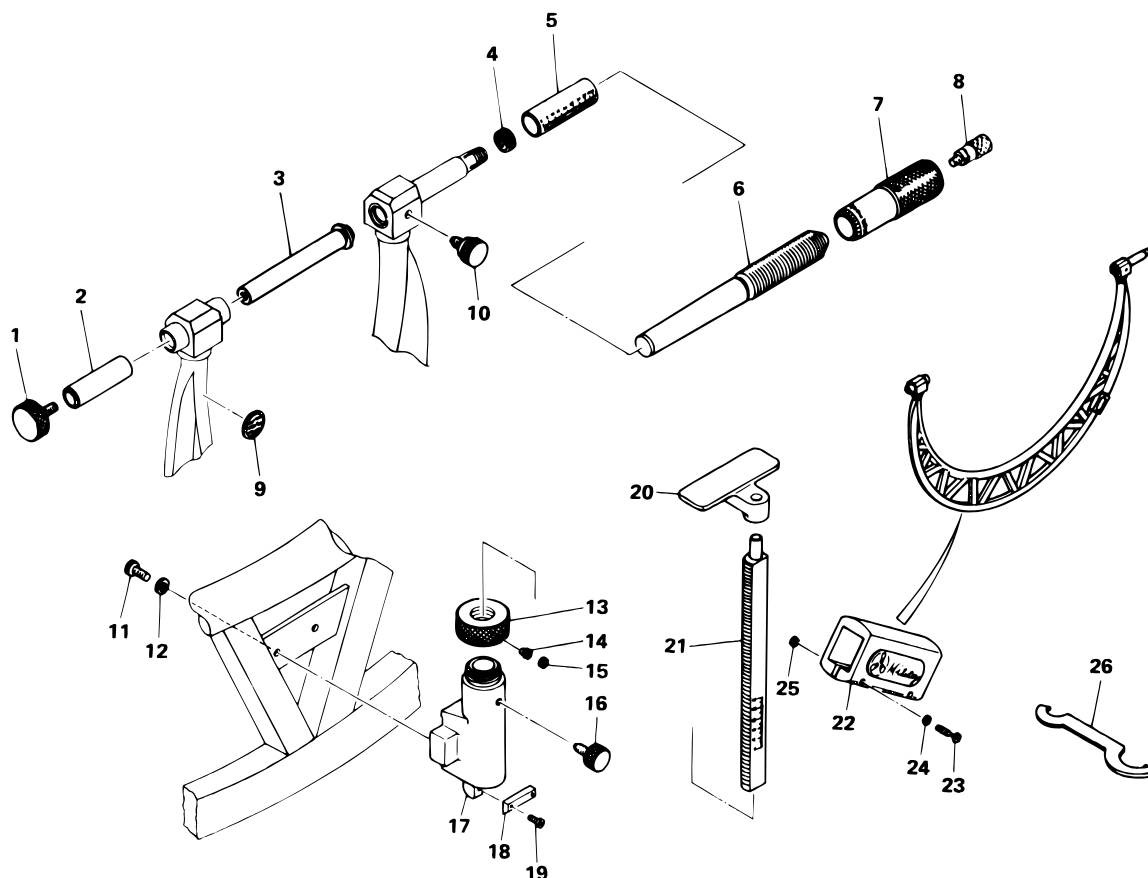

| KEY NO. | PART NAME | CODE NO. コードNo. | | | | | | | | | | | | | | ブリンメイ□ | キー No. | |
|---------|---------------------|-----------------------------------|-----------------------------------|-----------------------------------|-----------------------------------|-----------------------------------|-----------------------------------|-----------------------------------|-----------------------------------|-----------------------------------|-----------------------------------|-----------------------------------|-----------------------------------|-----------------------------------|-----------------------------------|----------------|----------|-----------------------------------|
| | | 105-408 (OMS ₁ -1100P) | 105-409 (OMS ₁ -1200P) | 105-410 (OMS ₁ -1300P) | 105-411 (OMS ₁ -1400P) | 105-412 (OMS ₁ -1500P) | 105-413 (OMS ₁ -1600P) | 105-414 (OMS ₁ -1700P) | 105-415 (OMS ₁ -1800P) | 105-416 (OMS ₁ -1900P) | 105-417 (OMS ₁ -2000P) | 105-418 (OMS ₂ -1200P) | 105-419 (OMS ₂ -1400P) | 105-420 (OMS ₂ -1600P) | 105-421 (OMS ₂ -1800P) | | | 105-422 (OMS ₂ -2000P) |
| 1 | CLAMP SCREW | 202196 | | | | | | | | | | | | | | シメツケネジ□ | 1 | |
| 2 | COLLAR 50MM | 202407 | | | | | | | | | | | | | | シンソクカラー 50MM□ | 2 | |
| 2 | COLLAR 100MM | | | | | | | | | | | | | | | シンソクカラー 100MM□ | 2 | |
| 3 | ANVIL | 203098 | | | | | | | 202406 | | | | | | | アンビル□ | 3 | |
| 4 | NUT, ADJ. | 200153 | | | | | | | | | | | | | | テーパナット□ | 4 | |
| 5 | SLEEVE | 200135 | | | | | | | | | | | | | | ガイドウ□ | 5 | |
| 6 | SPINDLE | 200152 | | | | | | | | | | | | | | スピンドル□ | 6 | |
| 7 | THIMBLE | 300451 | | | | | | | | | | | | | | シンブル□ | 7 | |
| 8 | RATCHET STOP | 950701 | | | | | | | | | | | | | | ラチェット□ | 8 | |
| 9 | NAMEPLATE | 303329 | 303330 | 303331 | 303332 | 303333 | 303334 | 303335 | 303336 | 303337 | 303338 | 303347 | 303348 | 303349 | 303350 | 303351 | ネームプレート□ | 9 |
| 10 | CLAMP SCREW | 303328 | | | | | | | | | | | | | | クランプ□ | 10 | |
| 11 | SET SCREW | 303363 | | | | | | | | | | | | | | ネジ□ | 11 | |
| 12 | WASHER | 303763 | | | | | | | | | | | | | | ザガネ□ | 12 | |
| 13 | NUT, STOPPER ADJ. | 303979 | | | | | | | | | | | | | | オクリナット□ | 13 | |
| 14 | KEY SCREW | 303358 | | | | | | | | | | | | | | キー□ | 14 | |
| 15 | SET SCREW | 303359 | | | | | | | | | | | | | | ネジ□ | 15 | |
| 16 | CLAMP SCREW | 303362 | | | | | | | | | | | | | | クランプ□ | 16 | |
| 17 | WORK STOPPER | 303978 | | | | | | | | | | | | | | シジホнтаイ□ | 17 | |
| 18 | PLATE | 303360 | | | | | | | | | | | | | | オサエイタ□ | 18 | |
| 19 | SET SCREW | 303361 | | | | | | | | | | | | | | ネジ□ | 19 | |
| 20 | PLATE, WORK STOPPER | 303352 | | | | | | | 303353 | | | | | | | セイゲンパン□ | 20 | |
| 21 | BAR, WORK STOPPER | 303976 | | | | | | | 303977 | | | | | | | メモリボウ□ | 21 | |
| 22 | COVER | 303339 | | | | | | | | | | | | | | ボウネットカバー□ | 22 | |
| 23 | SET SCREW | 303340 | | | | | | | | | | | | | | ネジ□ | 23 | |
| 24 | WASHER | 303342 | | | | | | | | | | | | | | ザガネ□ | 24 | |
| 25 | NUT | 303341 | | | | | | | | | | | | | | ナット□ | 25 | |
| 26 | SPANNER | 200154 | | | | | | | | | | | | | | スパナ□ | 26 | |

105 OUTSIDE MICROMETERS,
Series 105
Slide Anvil Type, Light Duty Pipe Frame

Ref. No. 105-2-1984-NOV

105シリーズ(OMS₁-P,OMS₂-P)
軽量パイプフレーム外側マイクロメータ
スライドアンビル式

105