

Micrometers

SERIES 293 – Digimatic Micrometer

- Easily integrated into a statistical process control or networked measurement system.
- Constant-force device: ratchet stop
- Interface Input Tools are available that enable the conversion of measurement data to keyboard signals that are then directly input to cells in off-the-shelf spreadsheet software such as Excel.
- Measuring faces: Carbide



293-782

SPECIFICATIONS

Inch/Metric					
Code No.	Range	Accuracy*1	Flatness	Parallelism	Price
293-782	300 - 325 mm (12 - 13")	±6 μm (±.0003")	0.6 μm (.000024")	5 μm (.0002")	£600.00
293-783	325 - 350 mm (13 - 14")				£602.00
293-784	350 - 375 mm (14 - 15")				£615.00
293-785	375 - 400 mm (15 - 16")	±7 μm (±.00035")		6 μm (.00024")	£622.00
293-786	400 - 425 mm (16 - 17")				£631.00
293-787	425 - 450 mm (17 - 18")				£644.00
293-788	450 - 475 mm (18 - 19")	±8 μm (±.0004")	7 μm (.00028")	£655.00	
293-789	475 - 500 mm (19 - 20")			£660.00	

* Excluding quantizing error.

DIMENSIONS

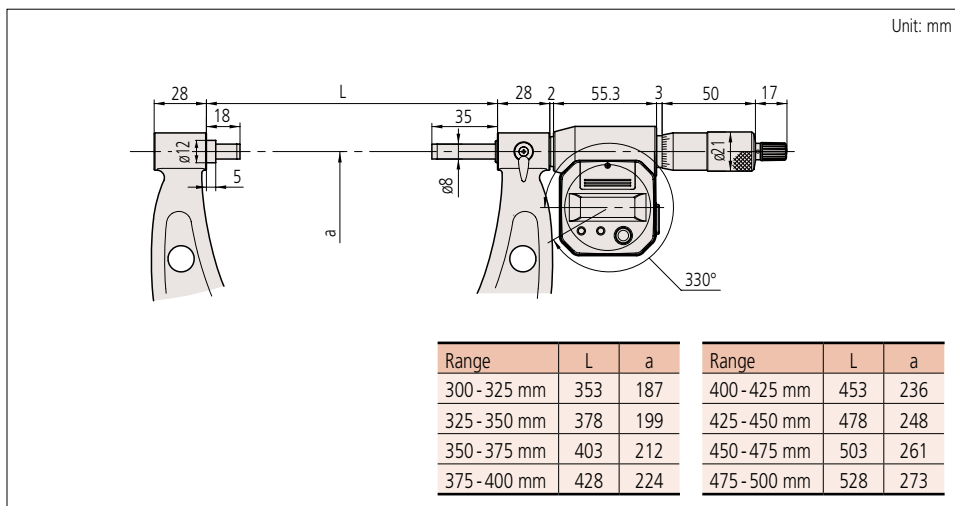

Technical Data

Resolution:	0.001 mm (.0001")
Measuring force:	10 to 15N
Battery:	SR44 (2 pcs) 938882
Battery life:	Approx. 1.8 years under normal use

Functions

Origin point setting (ABS measurement system):
Resets the ABS origin at the current spindle position to the minimum value of the measuring range and switches to ABS mode.

Zero setting (INC measurement system):
A brief press on the ZERO/ABS button sets display to zero at the current spindle position and switches to the incremental (INC) measuring mode. A longer press resets to the ABS measuring mode.

Hold:
Pressing the HOLD button freezes the current value in the display. This function is useful for preserving a measurement in situations of poor visibility where the instrument must be moved away from the workpiece before the reading can be recorded.

Function lock:
This function allows the ORIGIN (origin point setting) function and the ZERO (zero-setting) function to be locked to prevent these points being reset accidentally.

Auto power ON/OFF:
The reading on the LCD disappears after this instrument is idle for about 20 minutes, but the reading and measurement mode are retained. Turning the spindle causes the reading to reappear.

Data output:
Models equipped with this function have an output port for transferring measurement data to a Statistical Process Control (SPC) system.

Error alarm:
In the unlikely event of a display overflow or calculation error, an error message is displayed and measurement stops. Measurement cannot continue until the error is corrected. Also, if the battery voltage drops below a certain point, the battery indicator will turn on before measurement becomes impossible, warning the user that the battery needs to be replaced.

Optional Accessories

- 04AZB512:** L-type SPC data cable (1 m) **£65.00**
- 04AZB513:** L-type SPC data cable (2 m) **£68.00**
- 959149:** SPC data cable with pushbutton* (1 m) **£34.60**
- 959150:** SPC data cable with pushbutton* (2 m) **£39.40**
- 02AZD790E:** SPC data cable for U-WAVE-T (160 mm) **£52.20**

* May interfere with operating the thimble.