

SPECIFICATIONS

Inch/Metric						
Code No.	Range	Accuracy*1	Flatness	Parallelism	Mass	Price
293-676	0-30 mm (0-1.2")	±2 μm (±.0001")	0.3 μm (±.000012")	2 μm (.00008")	275 g	£247.00
293-677	25-55 mm (1-2.2")				355 g	£349.00
293-678	50-80 mm (2-3.2")	±3 μm (±.00015")		3 μm (.00012")	525 g	£375.00
293-679	75-105 mm (3-4.2")				625 g	£401.00

* Excluding quantizing error.

DIMENSIONS

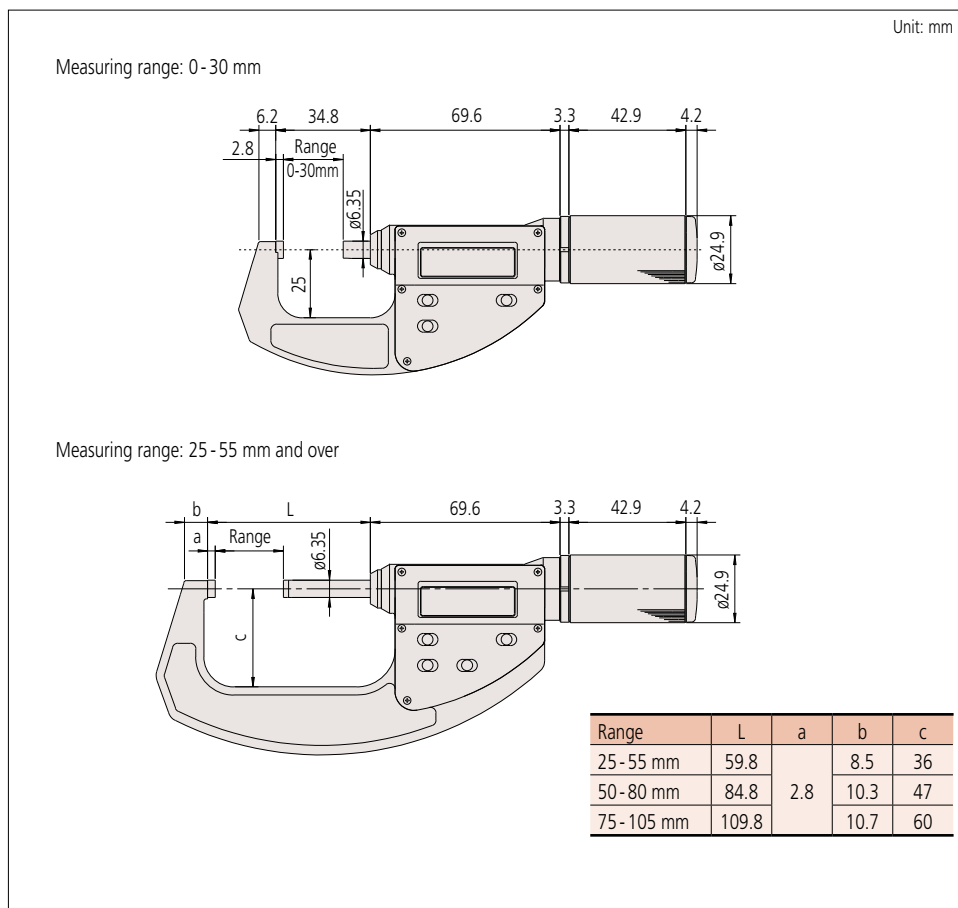

Non-rotating spindle

The non-rotating spindle enables even inexperienced operators to perform measurements repeatably and accurately.

