

Micrometers

SERIES 116 – Interchangeable Anvil Universal Micrometer

- Non-rotating spindle type which accepts seven forms of optional interchangeable anvils/spindle tips (flat, spline, spherical, point, knife-edge, disk, and blade) for a wide range of applications.
- Equipped with Ratchet Stop for constant measuring force.
- Optional anvils/spindle tips for screw thread measurement (matching V and cone) are also available.

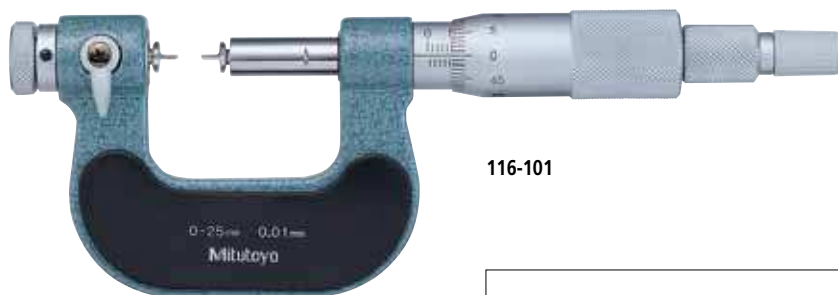

116-101



Interchangeable contact points (optional)

SPECIFICATIONS

Metric				
Code No.	Range	Graduation	Accuracy	Price
116-101	0 - 25 mm	0.01 mm	±4 μm	£221.00
116-102	25 - 50 mm			£291.00
Inch				
Code No.	Range	Graduation	Accuracy	Price
116-105	0 - 1"	.001"	±.0002"	£221.00
116-106	1 - 2"			£291.00

Note: 116-102 is provided with a plain setting standard (167-101) and a 60°-thread setting standard (167-261) for adjusting the minimum range point according to the application.

Technical Data

Spindle feed error: 3 μm / .00015"

Optional Accessories

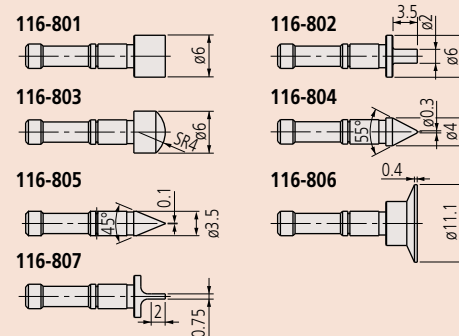

Interchangeable anvil/spindle tips (pair)

Code No.	Description	Price
116-801	Flat	£45.20
116-802	Spline	£24.00
116-803	Spherical	£24.00
116-804	Point	£24.00
116-805	Knife-edge	£24.00
116-806	Disk	£24.00
116-807	Blade	£45.20

Interchangeable anvil/spindle tips set

Code No.	Description	Price
116-800	Consists of 126-801 to 126-807	£314.00

Thread-measuring interchangeable contact points (pair)

Code No.	Metric	UNF	Price
116-831	0.4 - 0.5 mm	64 - 48 TPI	£36.00
116-832	0.6 - 0.9 mm	44 - 28 TPI	£45.20
116-833	1 - 1.75 mm	24 - 14 TPI	£45.20
116-834	2 - 3 mm	13 - 9 TPI	£36.00
116-835	3.5 - 5 mm	8 - 5 TPI	£36.00
116-836	5.5 - 7 mm	4.5 - 3.5 TPI	£36.00

Thread-measuring interchangeable contact points set

Code No.	Description	Price
116-830	Consists of 116-831 to 116-836	£270.00

